

Features

- Up to 90% efficiency
- Viewing angle: $2\theta_{1/2}=25^\circ$, $2\theta_{0.3}=35^\circ$

Typical Applications

- Reading lights (car, bus, aircraft)
- Uplighters/Downlighters
- Decorative/Entertainment
- Bollards/Security/Garden
- Cove/Undershelf/Task
- Indoor/Outdoor Commercial and Residential Architectural

Module Mechanical Dimensions

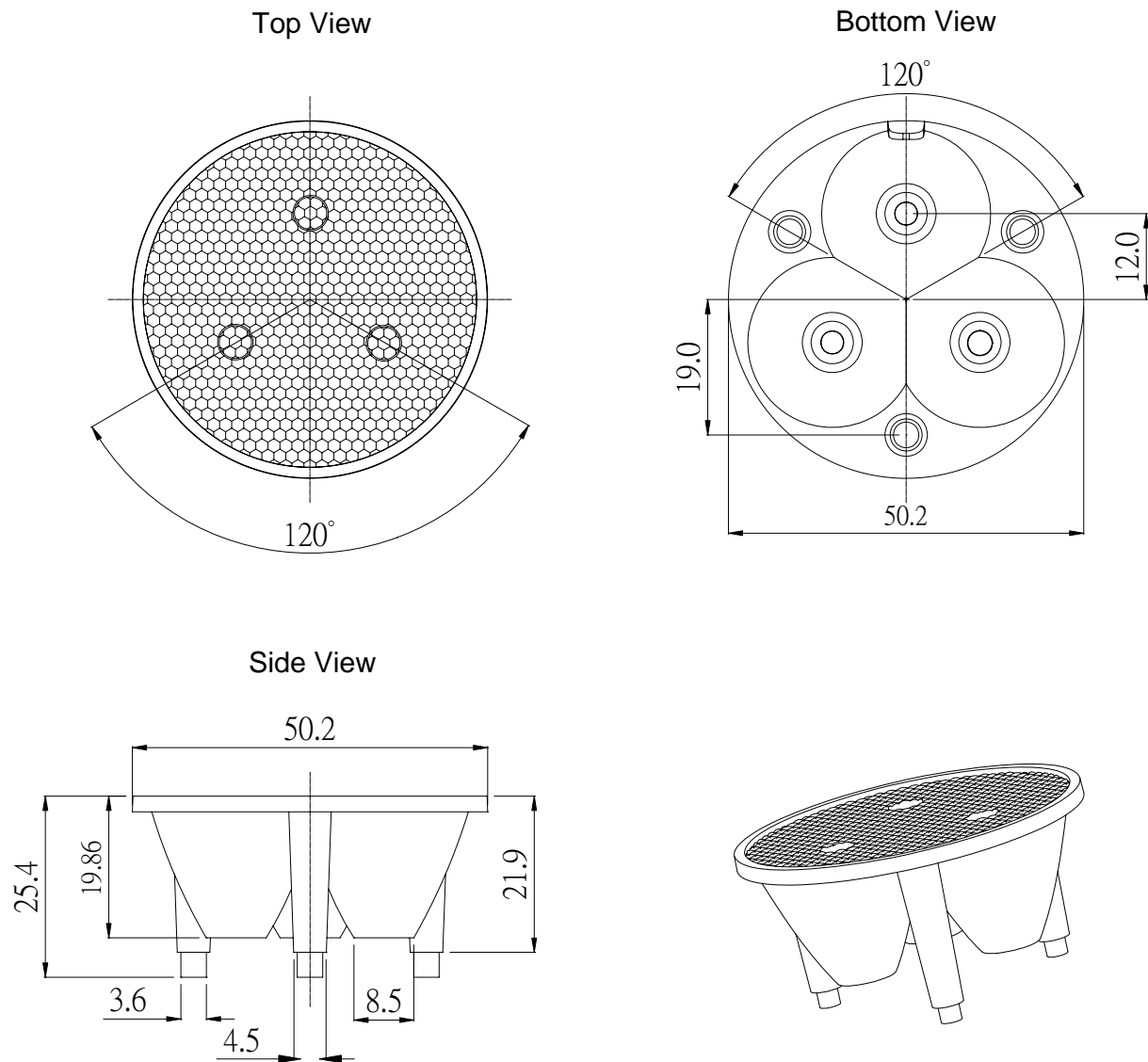

Notes:

1. All dimensions in millimeters and without tolerances are for reference only.
2. The ProLight light source must be protected from any axial or lateral loads caused by the collimator—do not clamp the collimator against the ProLight emitter.
3. Do not subject to temperatures greater than 75°C as plastic deformation may occur.
Protect collimator against exposure to solvents and adhesives that are not compatible with it.
Use care in handling the optic to avoid scratches or other damage that will effect the optical performance.

Representative Spatial Radiation Pattern

